

Bulk Material Handling Machine & Accessories

Big Bag Unloading Station Non-Std. Type

- Standard normal structure with monorail hoist and bag hanging device or fork lift holder , suit with any big bag sizes and non limited height cases
- Big bag normal support base hopper 45 to 70 degree angle on the vibration pad with vibrator or air knocker and bag opening window, option with small bag dumping door and air vent to dust collecting system

Big Bag Unloading Station Non-Std. Type

- Standard structure with monorail hoist and bag hanging device , suit with any big bag sizes and non limited height cases
- Plus Tout bin loading station, air piston operate
- Big bag docking for dust free operation and safety purpose in case of toxic dust
- Buffer / Feeding hopper with air vent to dust collecting system, 70 degree cone with vibrator or air knocker

Specifications

MODEL	CLOTH AREA (sq.m)	NO. TOP DOORS	OVERALL DIMENSIONS										COMPRESSED AIR REQUIRED @ 90 PSIG(SCFM)	FILTER APPROX. WT.(kg)	BIN VENT APPROX. WT.(Kg)
			A	B	C	D	E	F	G	H	J				
VM6-9	2	1	0.95	1	0.4	0.75	2.13	0.6	0.8	8	32	2	1.1	-	
VM9-9	4	1	0.95	1.3	0.4	0.75	2.43	0.9	0.8	8	32	2	2.2	-	
VM12-9	5	1	0.95	1.6	0.4	0.75	2.73	1.2	0.8	8	32	2	2.75	-	
VM9-16	7	1	1.2	1.5	0.45	0.8	2.85	0.9	1.04	9	36	3	3.85	-	
VM12-16	9	1	1.2	1.7	0.45	0.8	3.05	1.2	1.04	9	36	3	4.95	-	
VM15-16	12	1	1.2	2	0.45	0.8	3.35	1.5	1.04	9	36	3	6.6	-	
VM18-16	14	1	1.2	2.3	0.45	0.8	3.65	1.8	1.04	9	36	3	7.7	-	

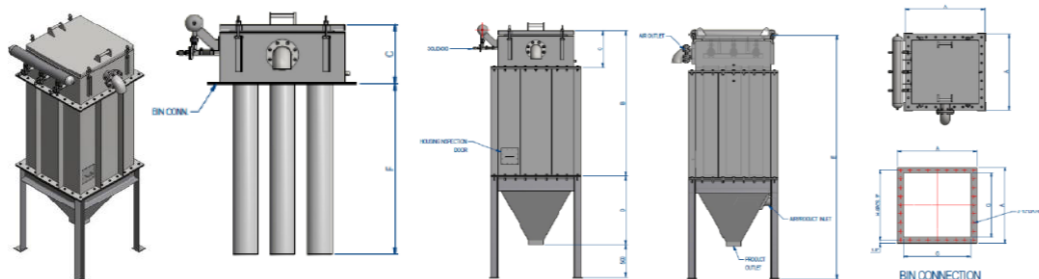

Many more option on request

www.thereccorp.com

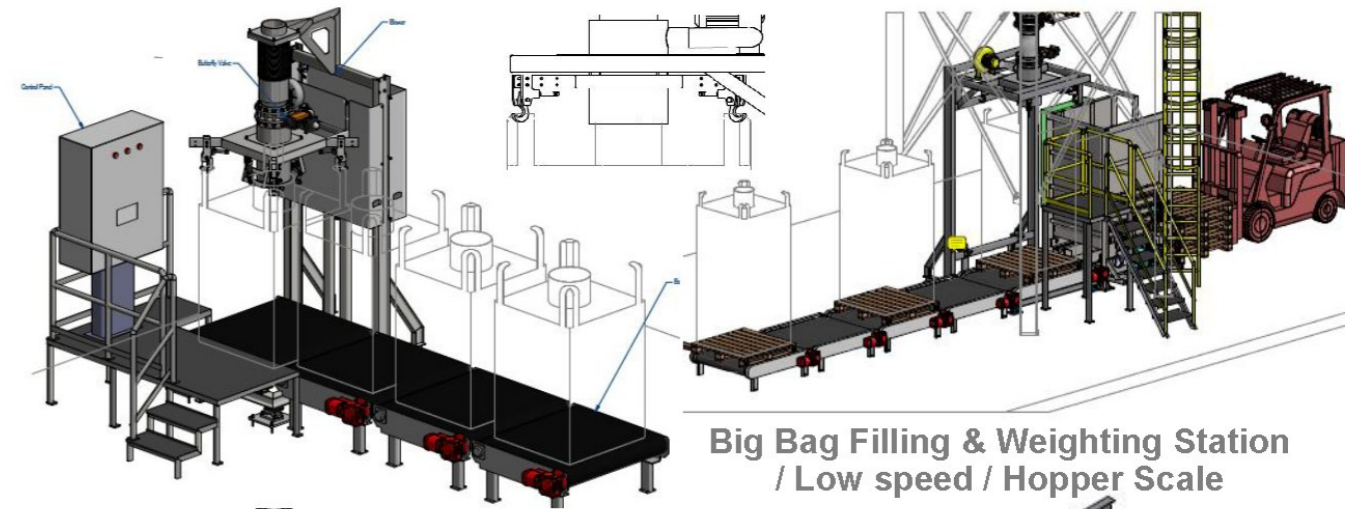

Big Bag Filling & Weighting Station / Low speed / Hopper Scale

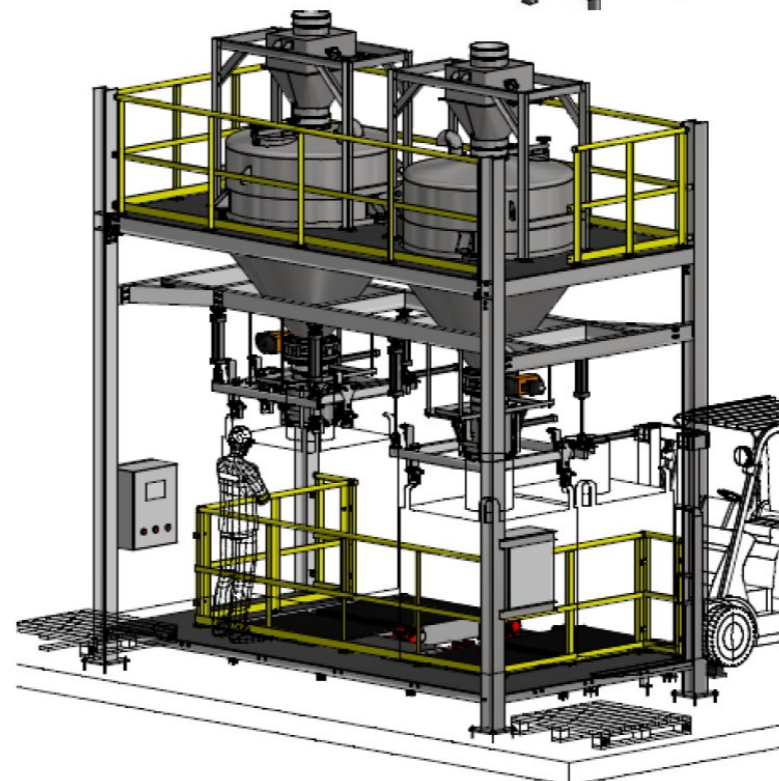

Big Bag Filling & Weighting Station / High Speed / Platform Scale

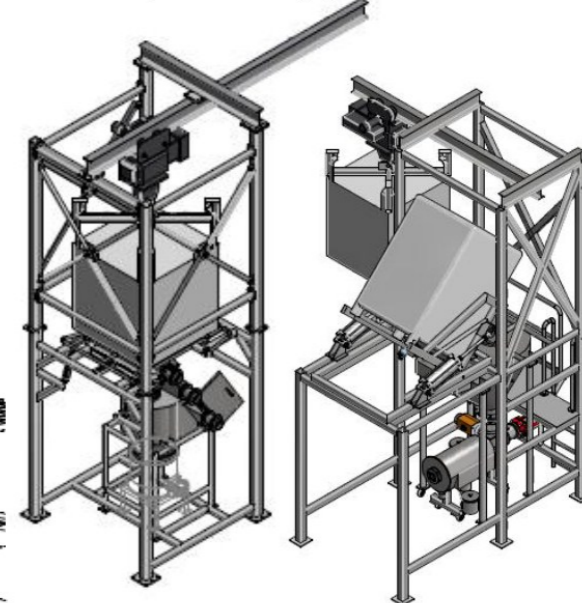

Big Bag Unloading Station



Bag Filter & Cyclone

Bag dump station

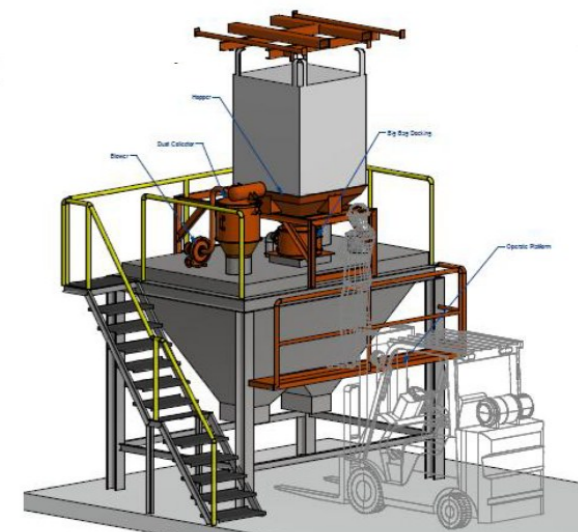

Our Own Production

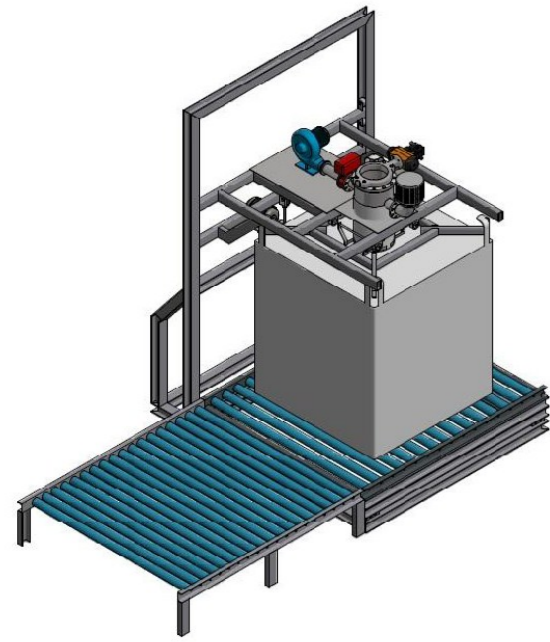

Big Bag Filling BBF-BW-A20

- Low speed big bag machine 10 – 20 bag / hr
- Standard feature / Big bag automatic lifting by screw jack , manual bag hanging device
- Could adjust to be suited with multi sizes of Big bag
- Installed with big bag blowing fan, roller conveyor and weighting scale
- Economical model to minimized the investment cost

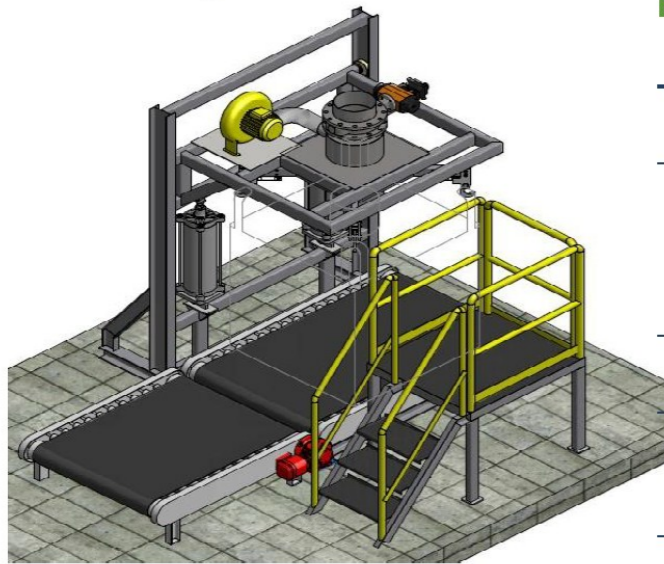

Big Bag Filling BBF-BW-B20

- Medium speed big bag machine 15 – 25 bag / hr
- Standard feature / Big bag automatic lifting by air piston, manual revolve hanging device with automatic hook
- Could adjust to be suited with multi sizes of Big bag
- Installed with big bag blowing fan, roller or belt conveyor and weighting scale
- Economical model to minimized the investment cost

Big Bag Filling BBF-BW-B20

- High speed big bag machine 30 to 50 bag / hr for single hopper machine and 50 to 100 bags/hr for twin hopper machine
- Weighting hoper and 2 step cut off vale for high precision weighting
- Standard feature / Big bag automatic lifting by air piston , Automatic sliding hanging device with automatic hook for operation safety
- Installed with big bag blowing fan, roller or belt conveyor , weighting hopper scale and double check weight station



Big Bag Unloading Station HT-C1T Type

- Standard normal structure with monorail hoist and bag hanging device , suit with any big bag sizes and non limited height cases
- Big bag normal support base hopper 45 to 70 degree angle on the vibration pad with or without vibrator or air knocker and bag opening window
- Buffer / Feeding hopper with air vent to dust collecting system, 45 to 70 degree cone



Big Bag Unloading Station HT-B1T Type

- Low loadings structure with integrated balancing spring and fork lift holder , for limited height cases bot for fork lift or for the building
- Big bag flat support base with bag massaging device
- Big bag docking for dust free operation and safety purpose in case of toxic dust
- Buffer / Feeding hopper with air vent to dust collecting system, 45 degree cone with vibrator or air knocker



Big Bag Unloading Station HT-A1T. Type

- Standard multi direction structure with monorail hoist and bag hanging device , suit with any big bag sizes and non limited height cases
- Big bag flat support base with bag massaging device
- Big bag docking for dust free operation and safety purpose in case of toxic dust
- Buffer / Feeding hopper with air vent to dust collecting system, 45 degree cone with vibrator or air knocker
- Feeding out flexible screw conveyor or aero mechanical conveyor on option