

# THEREC CORPORATION LTD.

Pneumatic Conveying & Bulk Material Processing  
Equipment, Components and Machines

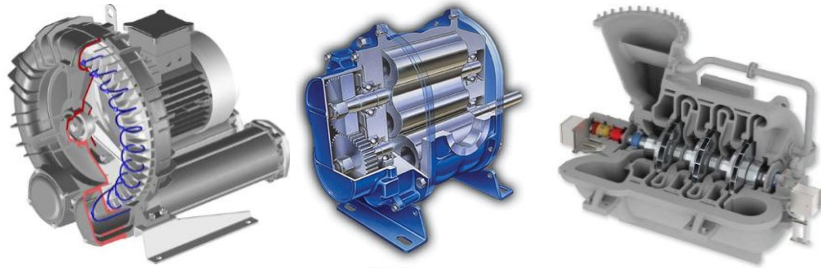

**High pressure blower  
Ring / Roots / Centrifugal**



**Air lock Rotary & Diverter valve  
Gate, Pinch and Butterfly valve  
Industrial and Food grade**



**Compression & Cam Lock  
couplings, Side glass**



**Flexible connecting & Flexible  
hose for bulk material handling**

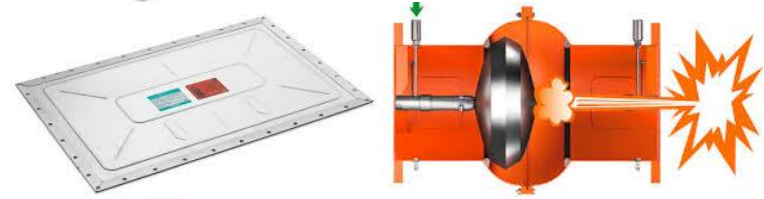

**Dust explosion protection  
equipment, Bursting panel &  
Isolated valve**



**Separator, Feeder, Mixer,  
Pulverizer, Grinder, Dryer**

*Imported Products*

[www.thereccorp.com](http://www.thereccorp.com)

บริษัท เทอร์เรค คอร์ปอเรชั่น จำกัด  
**THEREC**  
THEREC CORPORATION LTD.

# High Pressure Blowers and Vacuum pump



Multi stage centrifugal blower



Rotary vane vacuum pump



Turbotron



Regenerative / Ring blower



Positive displacement / Roots blower



Centrifugal blower



Flexible hose for air, gas and bulk material transferring



**D**  
Dust

**F**  
Fume



**A**  
Air



**D**  
Dust

**M**  
Light Weight  
Materials  
Handling



**F**  
Fume

**D**  
Dust

# Rotary and Diverter Valve ( European best seller valve)

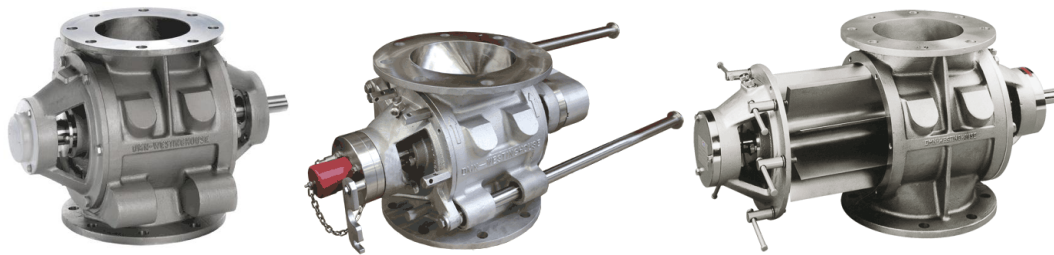

Drop Through Rotary valve / normal , quick detachable Food and dairy valve type

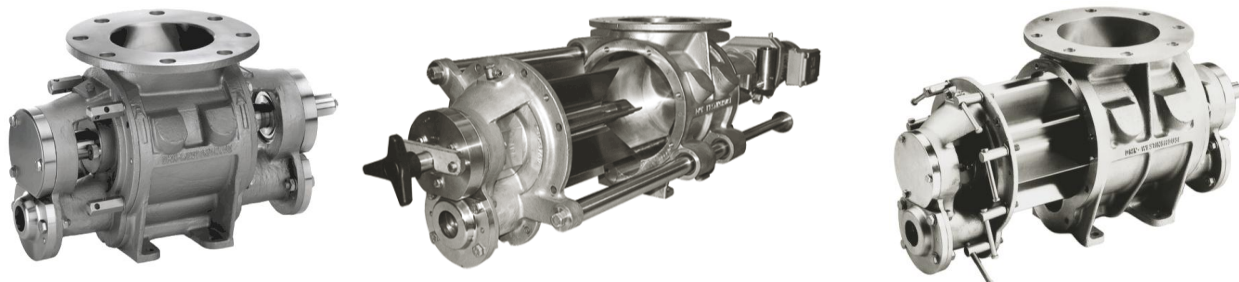

Blow Through Rotary valve / normal , quick detachable and dairy valve type

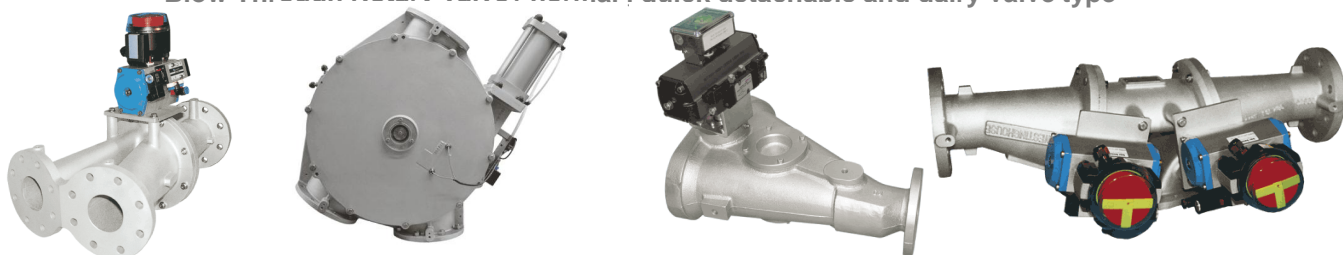

Diverter valve / Flap type , Plug type , Hammer type and Fill Vent valve

## Bulk material Handling Valve & Accessories



Pinch valve



Silo feeding Multi ways diverter valve



Cast iron and Stainless steel Slide gate valve



Pneumatic conveying pipe compression coupling and sight glass



*Our Quality Commitment*



[sale\\_trc@thereccorp.com](mailto:sale_trc@thereccorp.com)

# Bulk material Handling Accessories



Diverter valve



Cipriani Harrison Valves Pvt. Ltd.



Standard Sight Glass



Guarded Sight Glass

Sight glass

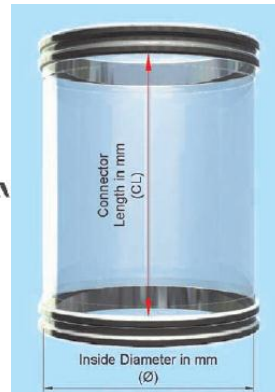

Seeflex Regulations - EC, FDA, USDA, 3A

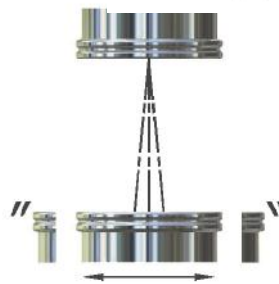
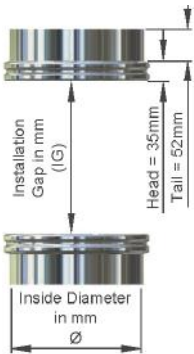

In-line static equipment  
IG = CL - 10mm  
(Minimum)

Off Set equipment  
IG = CL - 20mm  
(Minimum)

Oscillating equipment  
IG = CL - 40mm  
(Minimum)

## FROM THIS....



UNTIDY

DIFFICULT TO FIT

PRODUCT BUILD UP ISSUES

## TO THIS....



TIDY

EASY TO FIT

ELIMINATES ALL PRODUCT BUILD UP

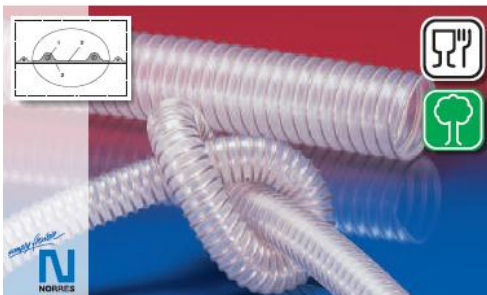
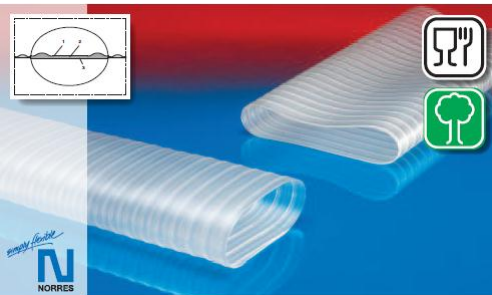

Sanitary/ Food grade flexible hose

simply flexible



TECHNISCHE SCHLÄUCHE  
INDUSTRIAL HOSES



# Dust Explosion Protection Equipment

VIGILEX®  CE



Bursting panel



Flame Arrestor

## Explosion Isolation Equipment

- Active Quick Sliding valves
- Passive Barrier valves
- Explosion diverters
- Extinguishing barriers



## Explosion Suppression Equipment

- Pressure detection (dynamic/static)
- Infrared detection
- Suppression systems with reusable valves
- Hot Water Advanced Inserting Systems
- ATEX Powder Suppression

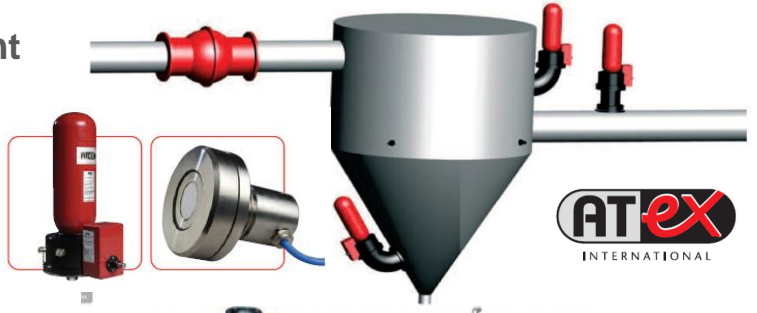

## Hosokawa Micron / NUATA MIXER

The newly born, Best seller, powder mixer  
Over 10,000 units of reference worldwide

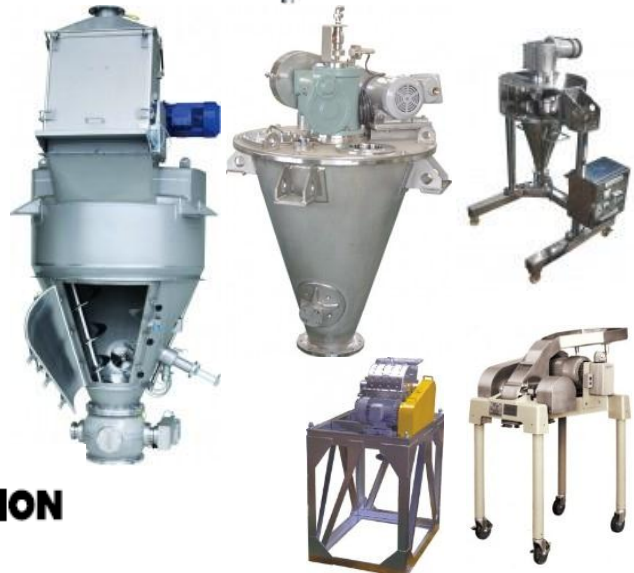
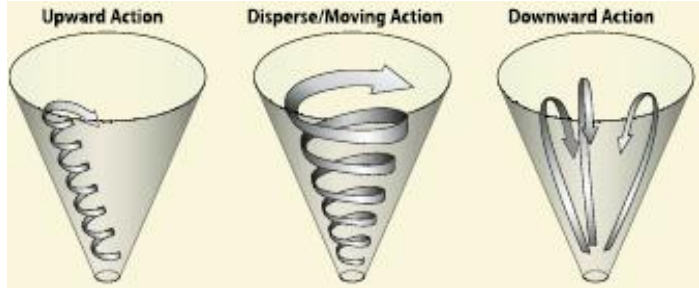

Process Technologies for Tomorrow

**HOSOKAWA MICRON CORPORATION**

Hammer Mill, Feather Mill / Coarse particle



Many Types of machines for fine and ultra fine material



[sale\\_trc@thereccorp.com](mailto:sale_trc@thereccorp.com)

# Bulk material Handling Valves & Component



Quick detachable / Normal / Slide arm, Easy clean Food grade Rotary Feeder in Stainless Air lock type and Feeding type



Quick detachable , Easy clean, Food grade, Screw Feeder in SUS 304 ,316



Easy Clean, Food grade, Lump Breaker



Quick detachable , Movable , Food grade, Screw Feeder in SUS 304 ,316



Easy Clean, Food grade, Magnetic Separator



Long Bends & Venture

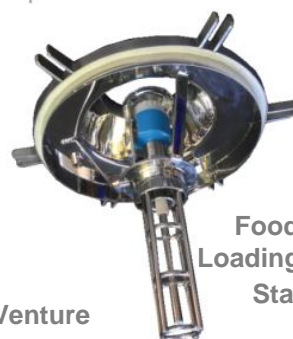

Food grade, Loading Bellow in Stainless



Food Sampling Valve



Food grade, Diverter Valve



# Bulk Bag Handling Machines & Component

BAG FILLING STATION

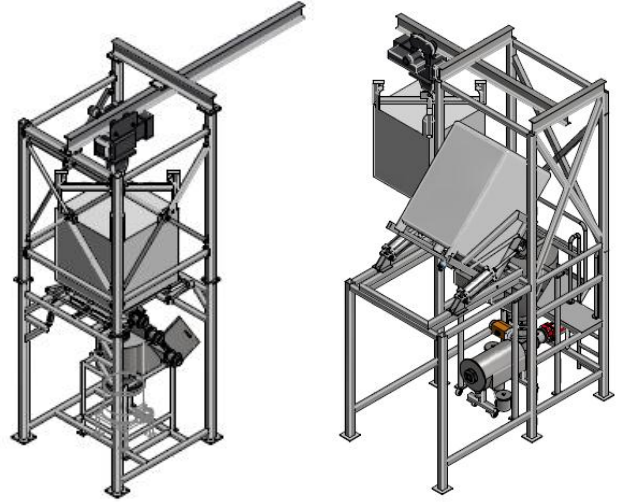
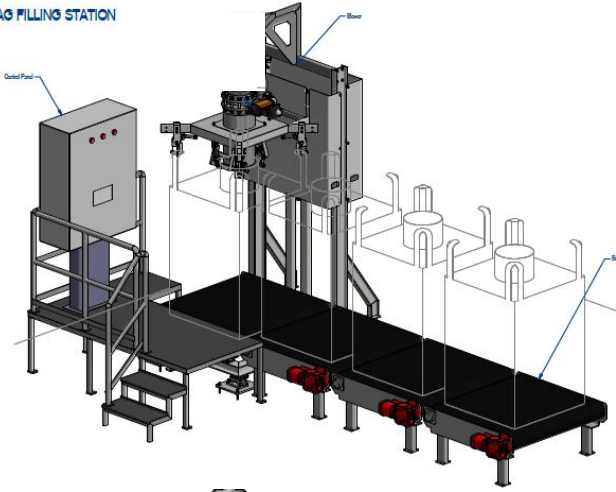

Big Bag & Tote bin Unloading Station

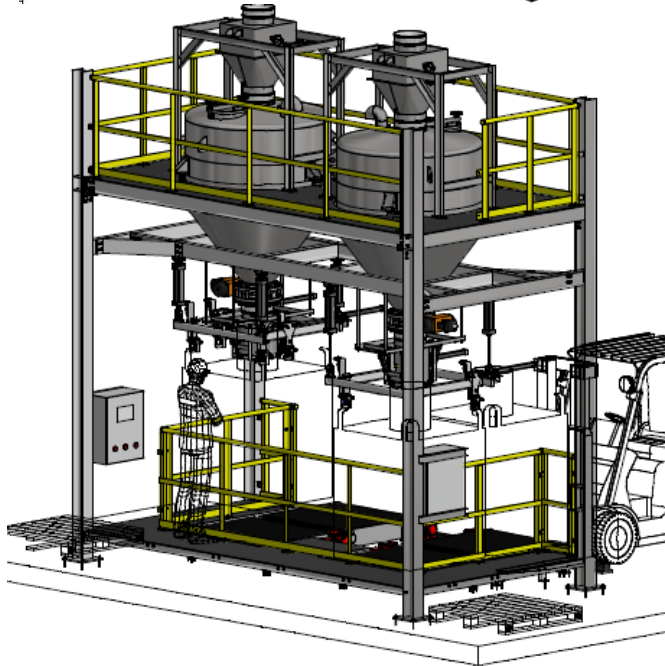

Big Bag Filling & Weighting Station / High & Low Speed / Platform Scale & Hopper scale

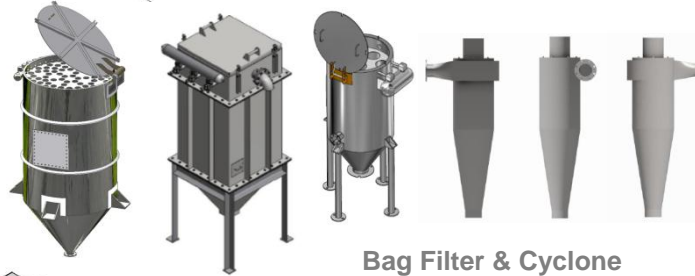
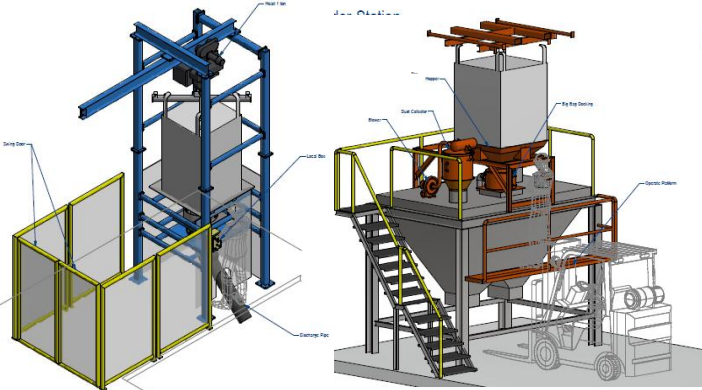

Bag Filter & Cyclone



Small Bag dumping station

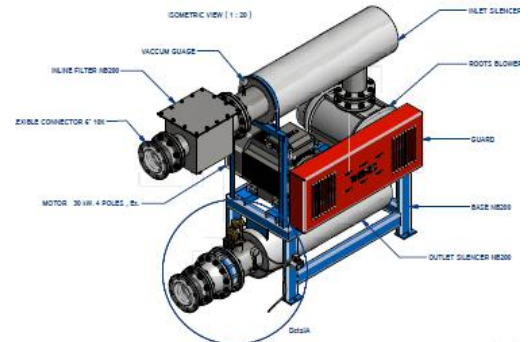

Acoustic Enclosure & Blower package

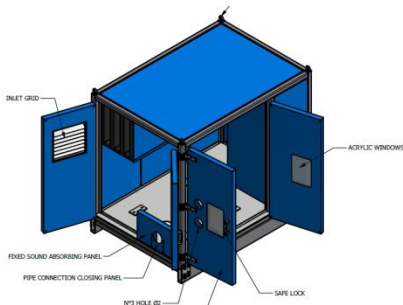

# THEREC CORPORATION LTD.

## Manufacturing product categories

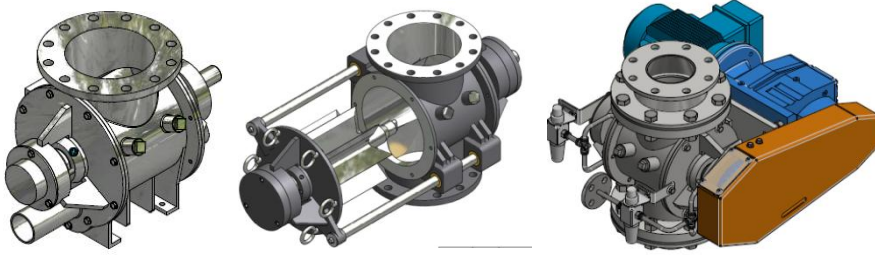

**Air lock Rotary valve**



**Diverter valve**

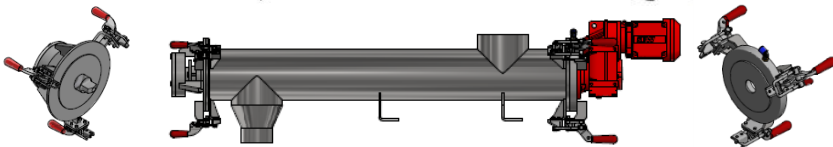

**Easy clean Screw Conveyor**

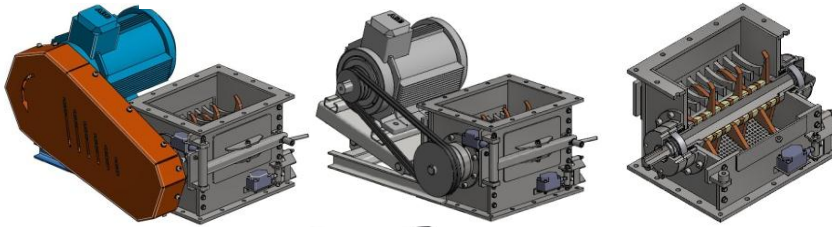

**Lump Breaker**



**Big Bag & Small Bag Unloading (Tipping) Station**

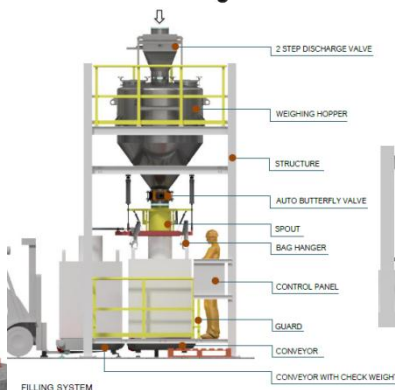

**Big Bag Filling & Weighting Station**



STEP 1



Tel : 662 893 9003-4 Fax : 662 893 9178 / E-mail : sales\_trc@thereccorp.com

*Manufacturing Products*

[www.thereccorp.com](http://www.thereccorp.com)

บริษัท เทอร์เรค คอร์ปอเรชั่น จำกัด  
**THEREC**  
THEREC CORPORATION LTD.